

Essential Filing Cabinet

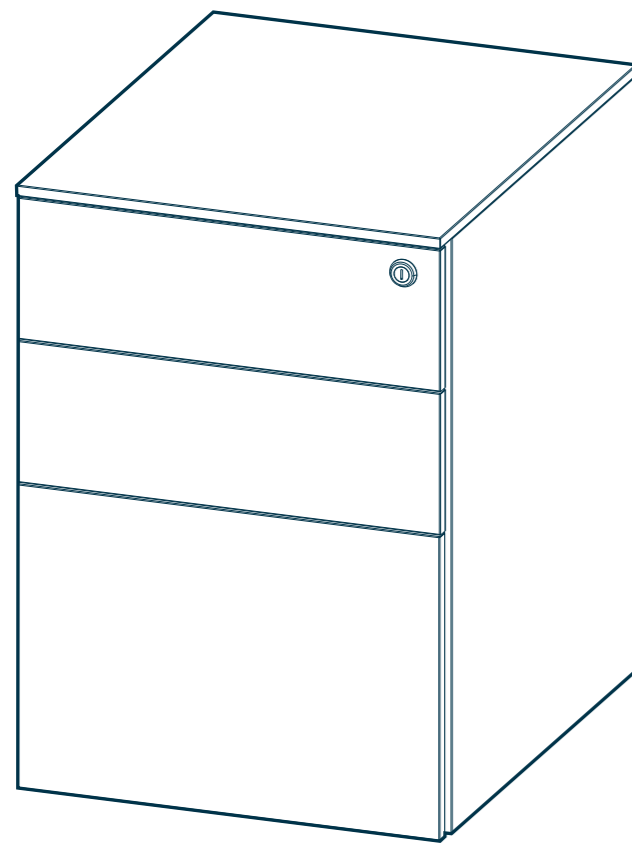

2 People
Recommended

vari®



FILING CABINET
x1



KEY
x1

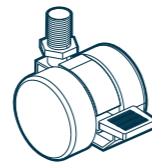

LOCKING CASTERS
x2

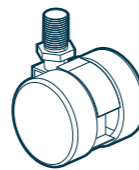

CASTERS
x2



10MM LOCK WASHER
x4



ANTI-TIP CASTER
x1



M4 X 10 PHILLIPS
HEAD SCREW
x2

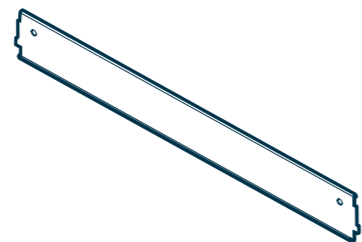

FILING BAR
x1

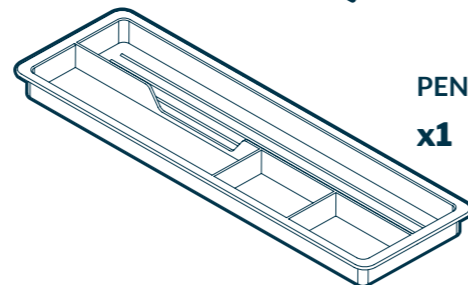

PENCIL TRAY
x1

Tools Needed



14MM WRENCH
x1



PHILLIPS HEAD
SCREWDRIVER
Not Included

1

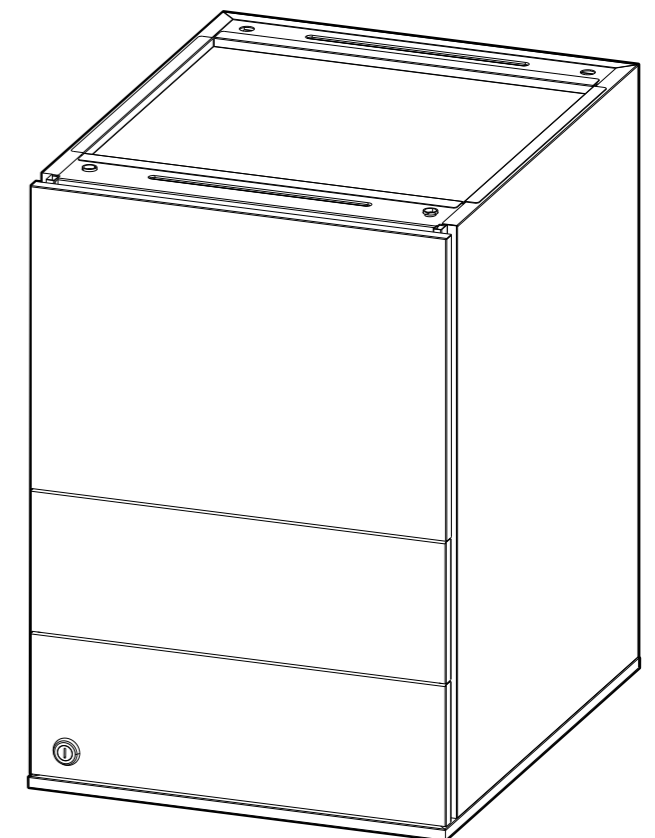
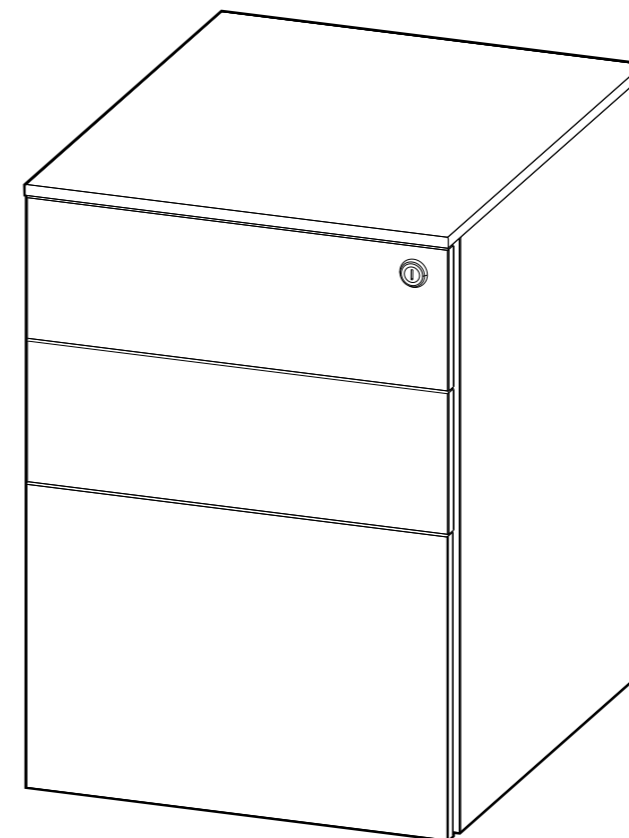

Remove the filing cabinet from the box, and set it on the ground in the upright position (with the lockable drawer at the top). Unlock the filing cabinet, and remove the hardware kit from the second drawer. Close and relock the filing cabinet.

With the help of another person, lift and rotate the filing cabinet until it is upside down, then set down gently. To prevent surface scratches, this step should be completed on carpet or a blanket.

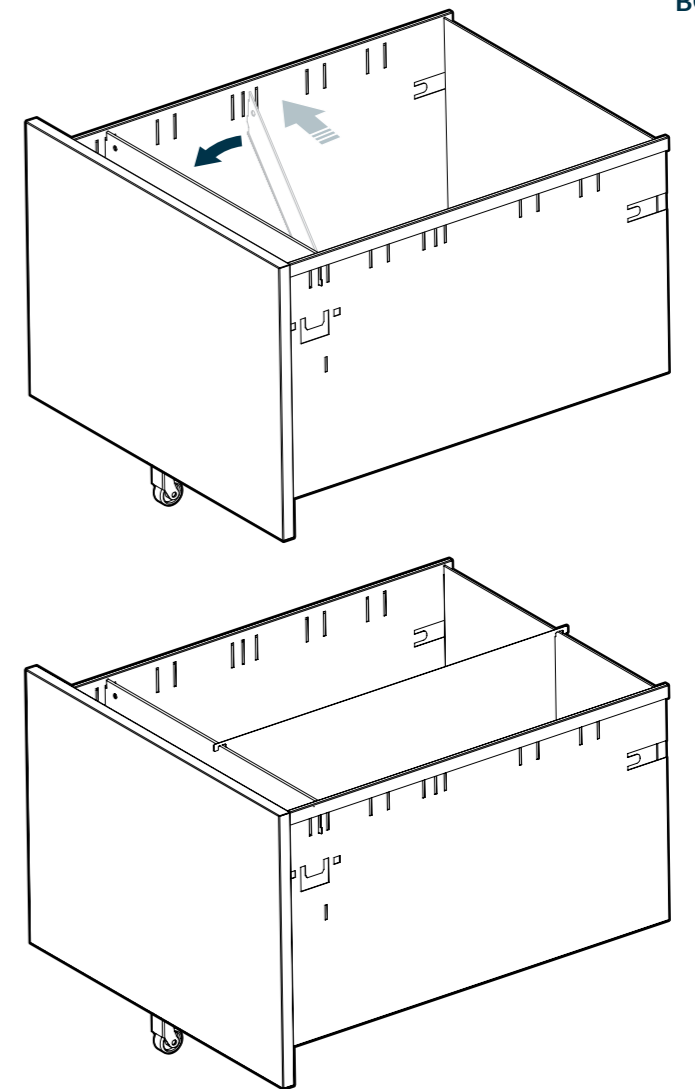
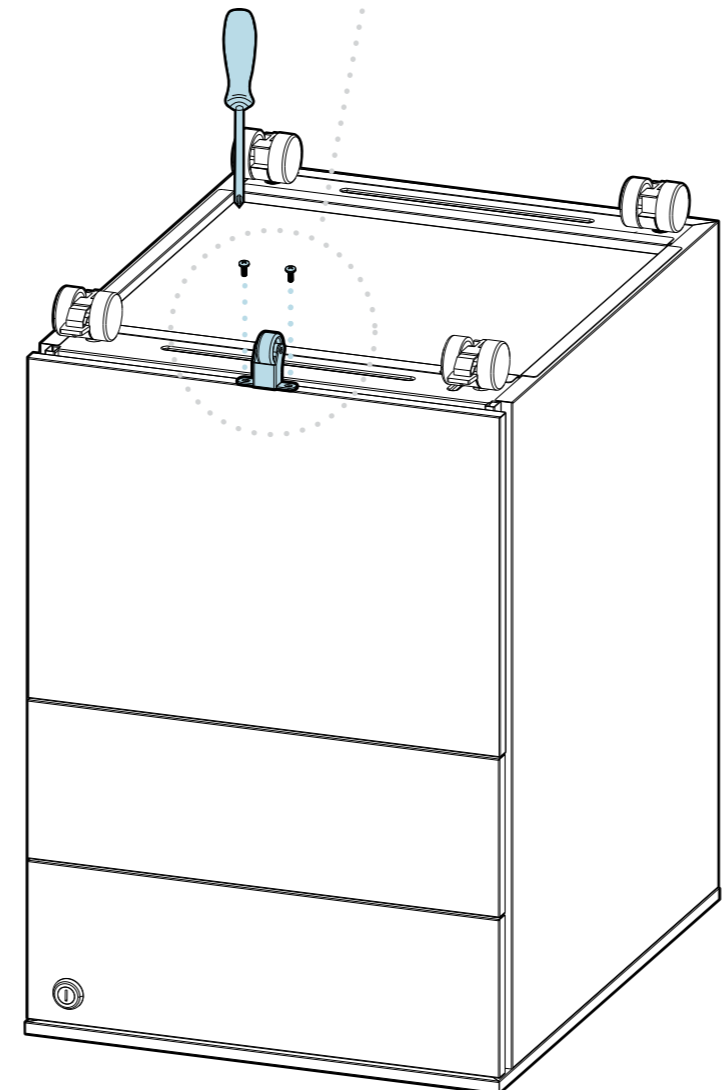
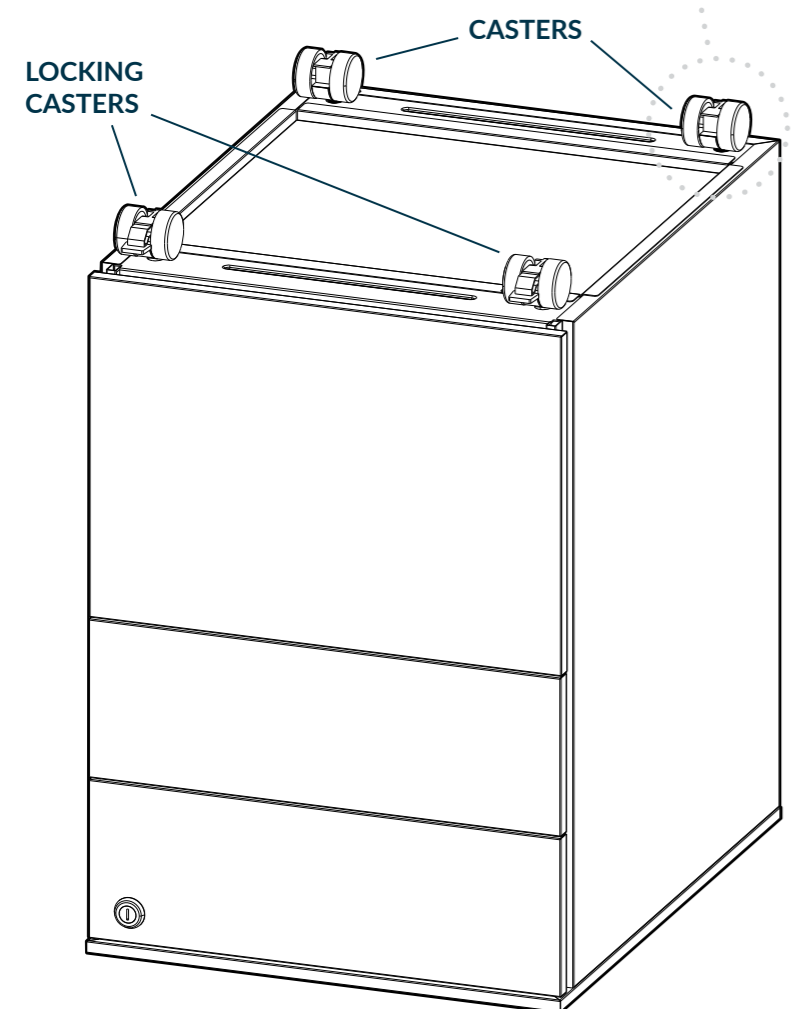
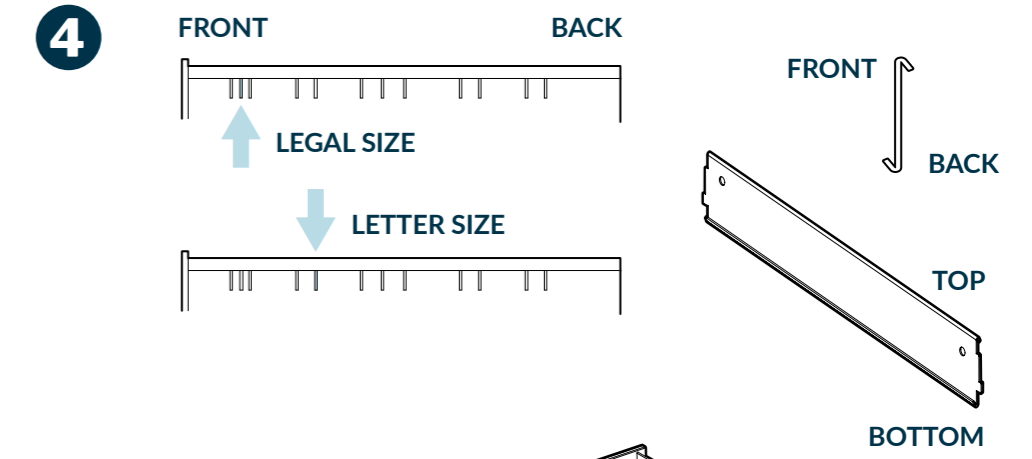
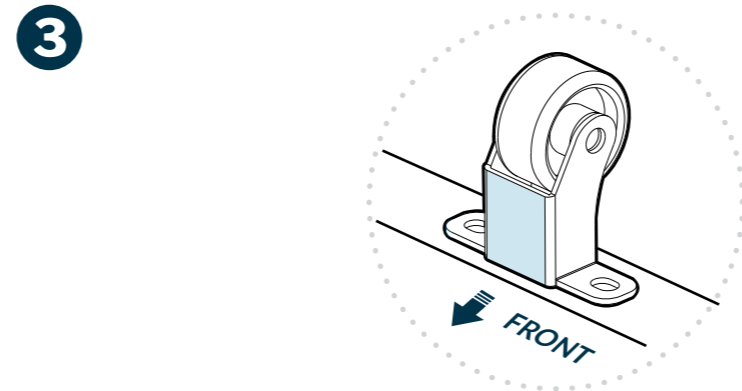
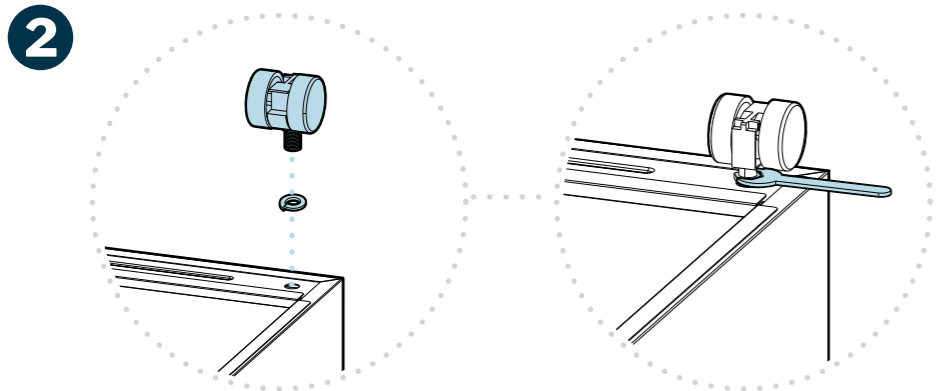

Insert the threaded caster post through a lock washer and into the filing cabinet's threaded inserts. **NOTE: As shown above, the locking casters should be placed in the front two inserts, and the standard casters should be placed in the back two inserts.**

Begin threading the built-in bolt at the base of the caster post by hand-spinning the bolt clockwise, and then finish tightening with the provided wrench. Repeat until all four casters are securely installed.

Place the anti-tip caster on the bottom edge of the large drawer, aligning it with the pre-drilled holes and with the wheel turned away from the front of the filing cabinet. Use a Phillips head screwdriver to tighten the screws.

Confirm that the two locking casters are in the locked position, then (with the assistance of a second person) lift and rotate the cabinet into an upright position and set it down gently on the casters.

Unlock the file cabinet, and insert the pencil tray in the desired place in the top drawer.

To install the filing bar, refer to the above diagram for proper positioning and placement. With the bar in the proper position, lower it into the drawer, place one end in the desired side slot, and horizontally rotate the bar until the second end is in its corresponding slot. You might need to gently push the second side of the drawer outward to allow room for the bar to rotate. Files will hang front-to-back in the drawer.

CAUTION: WEIGHT CAPACITIES

- First Drawer: 22 lb (10 kg)
- Second Drawer: 22 lb (10 kg)
- Third Drawer: 44 lb (20 kg)
- Top of Cabinet: 110 lb (50 kg)

(800) 207-2587